

Configuration	
Description	Property value
Type	Compacta AG160
Mains	Three-phase current
Mains frequency	50 Hz
Y-Connection	Yes
Supply voltage	230 / 400V AC
Supply connection	3 x 400V AC
Output speed rpm	1,8 min ⁻¹
Output torque in Nm / Duty cycle (ED) in %	1530 Nm / 60%
Self locking	No
Ratio	765 : 1
Lubrication	TRIBOL 800/680
Limit switch range	0,25 revolutions on output
Protection class	IP54
Motor rating	0,6 kW
Current value	1,6 A
Equipment	
Spring applied brake 2 Nm / 400 V AC	

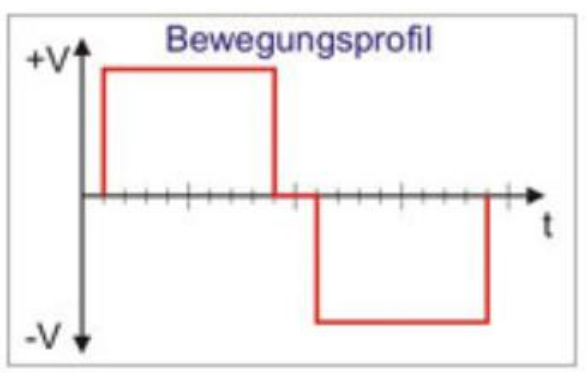

Safeguarded by 2 safety limit switches without reversing contactors for applications with a defined end position in both directions of rotation.

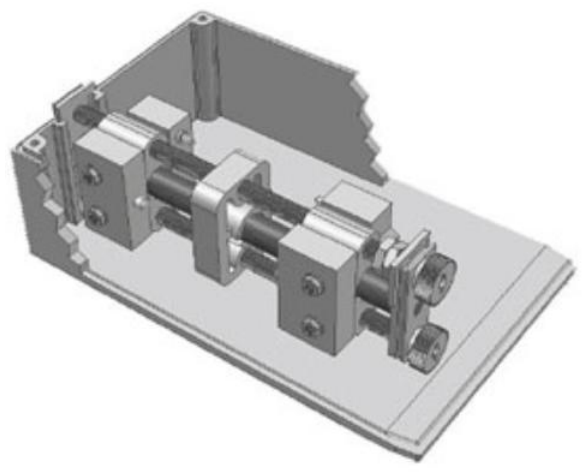
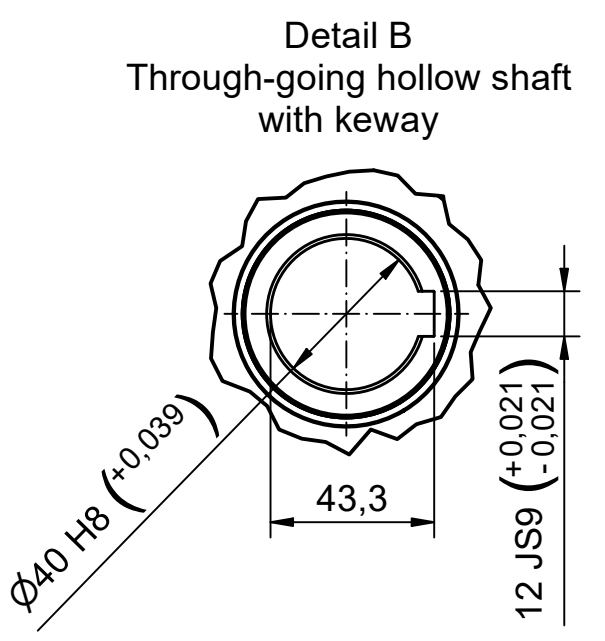
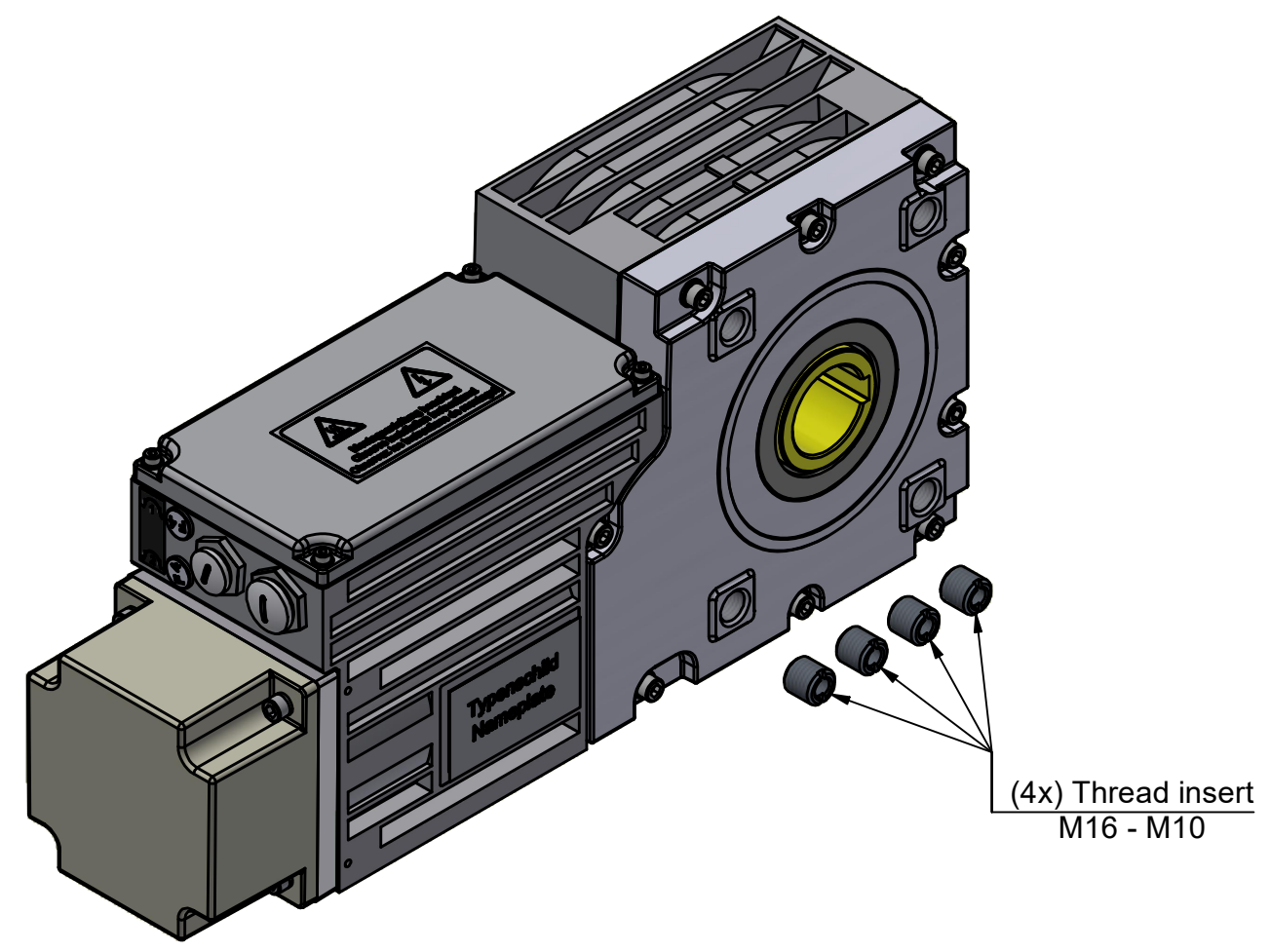

Bezeichnung / designation		
Compacta AG160 Induction Motor		
Datenblatt / technical datasheet		
10000000000166692		 Franz Morat Group
Artikel Nr. / article no. 6-160-AG-0007		
gezeichnet / drawn	Datum / date 12.01.2024	Name / name mwid
Framo Morat GmbH & Co. KG Franz-Morat-Straße 6 D-79871 Eisenbach www.framo-morat.com		