

Configuration	
Description	Property value
Type	Compacta AG160
Mains	Three-phase current
Mains frequency	50 Hz
Y-Connection	No
Supply voltage	230 / 400V AC
Supply connection	3 x 230V AC
Output speed rpm	0,45 min-1
Output torque in Nm / Duty cycle (ED) in %	1600 Nm / 60%
Self locking	dynamic
Ratio	3111 : 1
Lubrication	TRIBOL 800/680
Limit switch range	0,5 revolutions on output
Protection class	IP54
Motor rating	0,6 kW
Current value	2,65 A
Equipment	
Hand crank with electric protection	

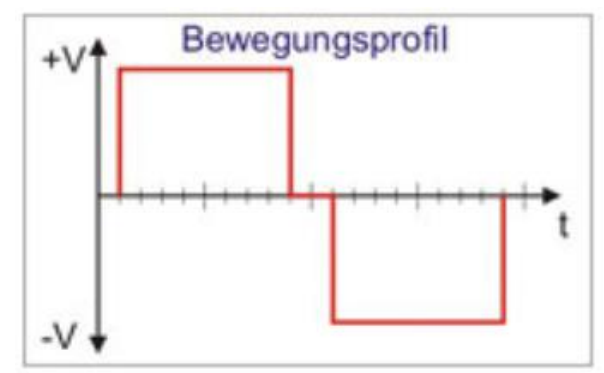

Safeguarded by 2 safety limit switches with integrated motor reversing contactors for applications with a defined end position in both directions of rotation.

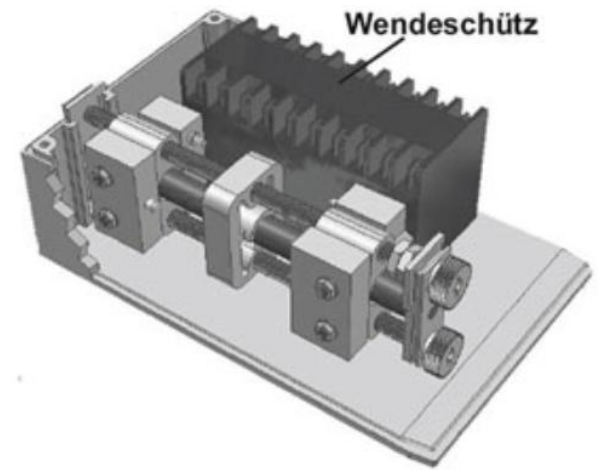
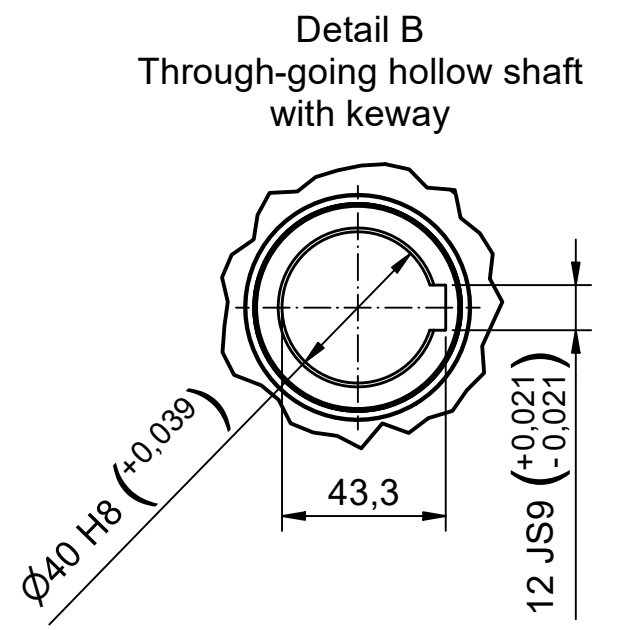
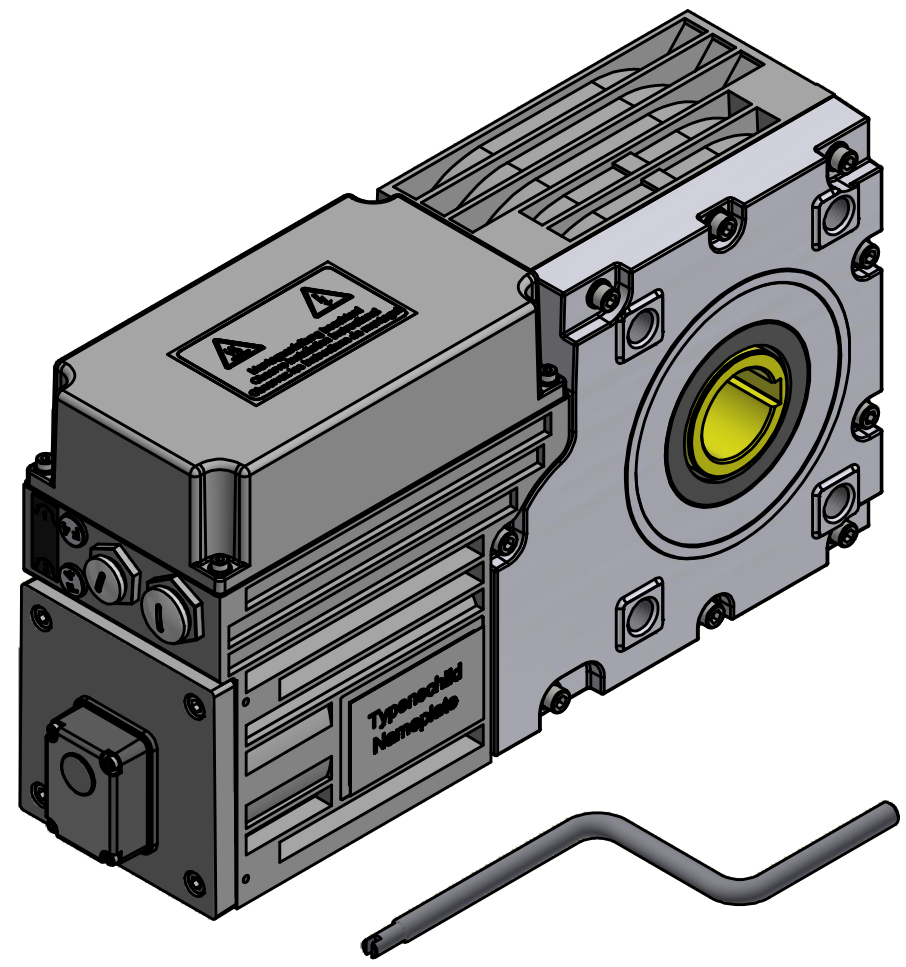

Bezeichnung / designation		
Compacta AG160 Induction Motor		
Datenblatt / technical datasheet		
10000000000162593		 Franz Morat Group
Artikel Nr. / article no.		
6-160-AG-0001		Framo Morat GmbH & Co. KG Franz-Morat-Straße 6 D-79871 Eisenbach www.framo-morat.com
Datum / date	Name / name	
gezeichnet / drawn		
13.10.2023	mwid	