

Configuration	
Description	Property value
Type	Compacta MS12
Mains	Alternating current
Mains frequency	50 Hz
Y-Connection	No
Supply voltage	230V AC
Supply connection	1 x 230V AC
Motor condenser	16 µF
Output speed rpm	12,1 min-1
Output torque in Nm / Duty cycle (ED) in %	65 Nm / 20%
Self locking	static
Ratio	114 : 1
Lubrication	TRIBOL 800/680
First gear stage	Plastic
Limit switch range	38 revolutions on output
Protection class	IP54
Motor rating	0,25 kW
Current value	1,80 A
Equipment	
Slide potentiometer 1 kOhm	

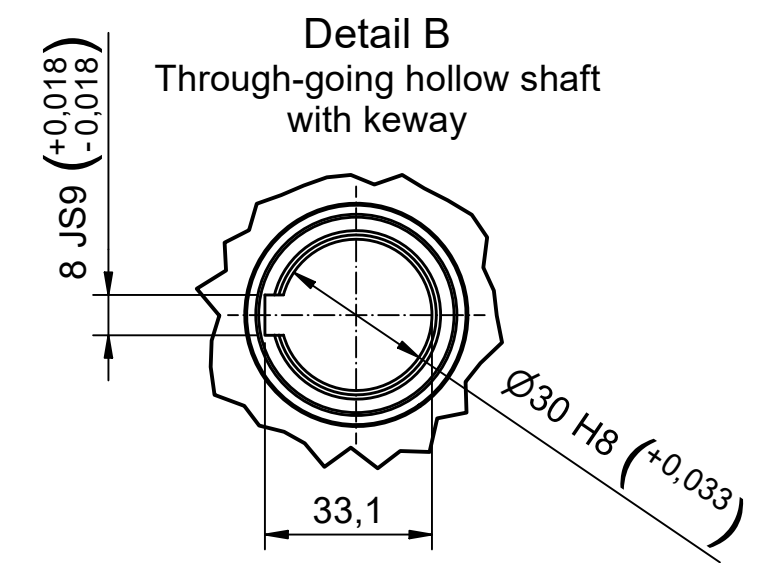
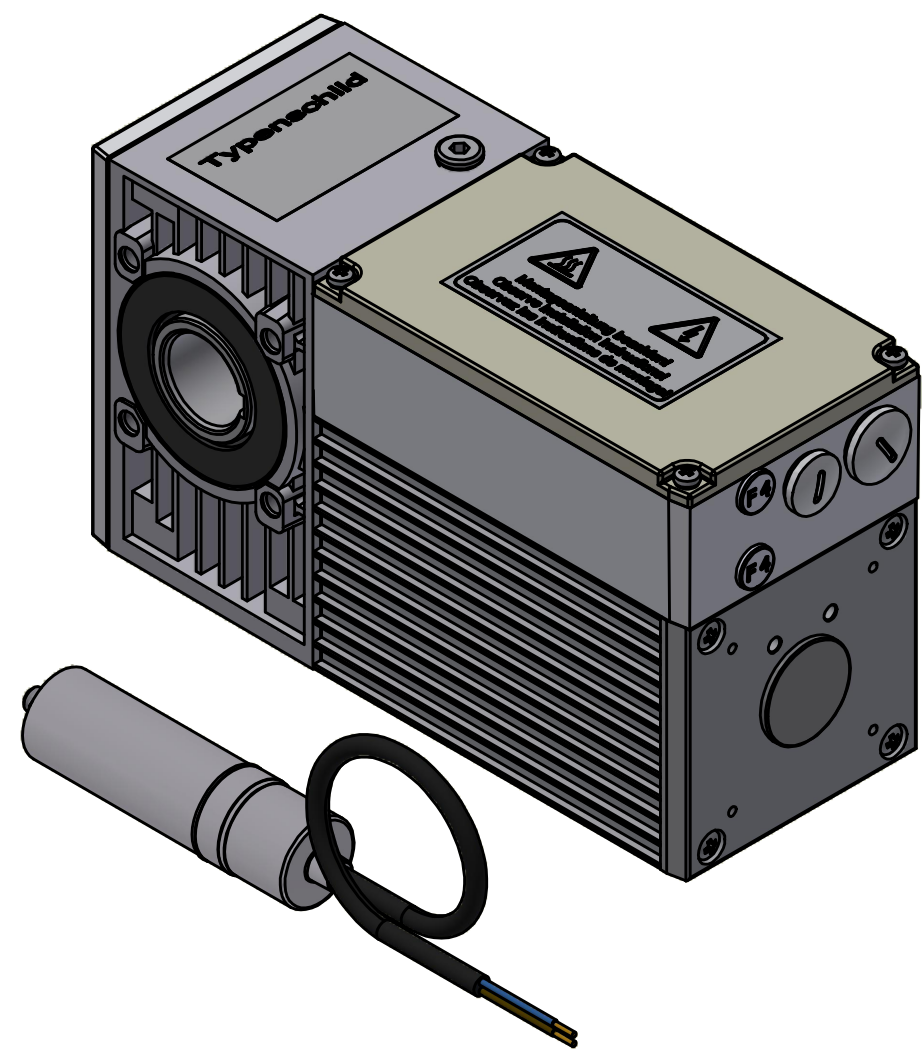
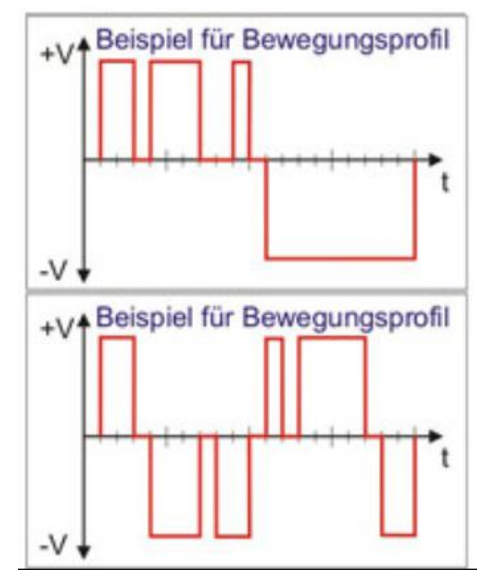
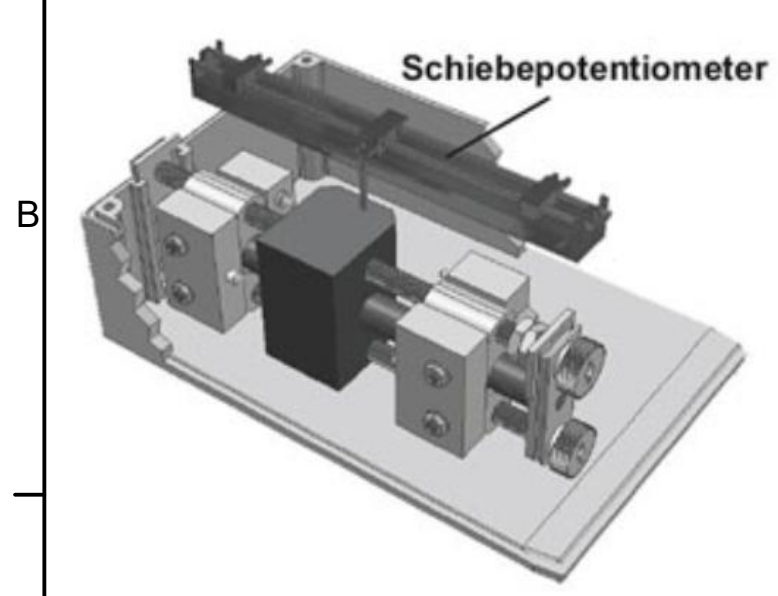

Safeguarded by 2 safety limit switches for applications with a defined end position in both directions of rotation.

Additional position signal using linear potentiometers.

Bezeichnung / designation		Compacta MS12 Induction Motor	
Datenblatt / technical datasheet			
10000000000162365		 FramoMorat Franz Morat Group	
Artikel Nr. / article no. 6-12-MS-0029			
gezeichnet / drawn	Datum / date 13.12.2023	Name / name mwid	Framo Morat GmbH & Co. KG Franz-Morat-Straße 6 D-79871 Eisenbach www.framo-morat.com