

Connection:  
tapped hole  
M16x1,5 + M20x1,5

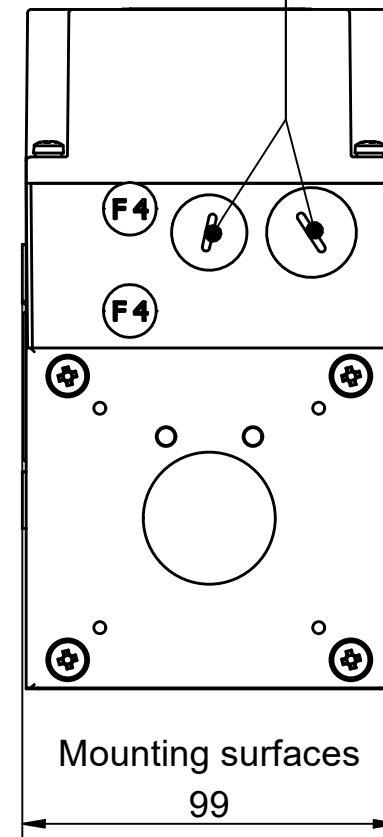

Configuration	
Description	Property value
Type	Compacta MS12
Mains	Three-phase current
Mains frequency	50 Hz
Y-Connection	Yes
Supply voltage	230/400V AC
Supply connection	3 x 400V AC
Output speed rpm	68,0 min-1
Output torque in Nm / Duty cycle (ED) in %	39,5 Nm / 40% 29,5 Nm / 60%
Duty cycle according to nameplate	40%
Self locking	No
Ratio	40,5 : 1
Lubrication	TRIBOL 800/680
First gear stage	Plastic
Protection class	IP54
Motor rating	0,4 kW
Current value	1,25 A

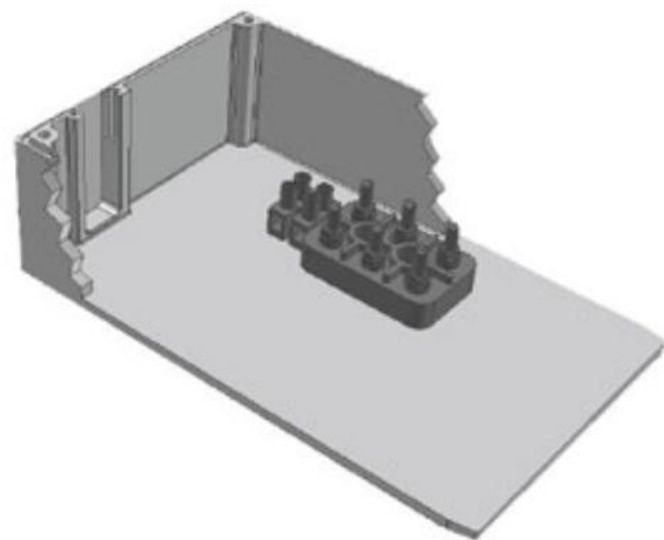

Terminal box (limit switch housing without a switching mechanism).

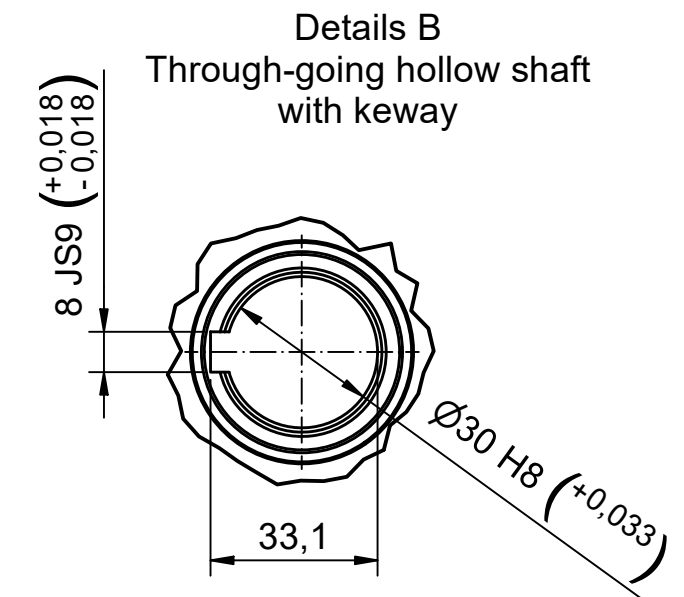
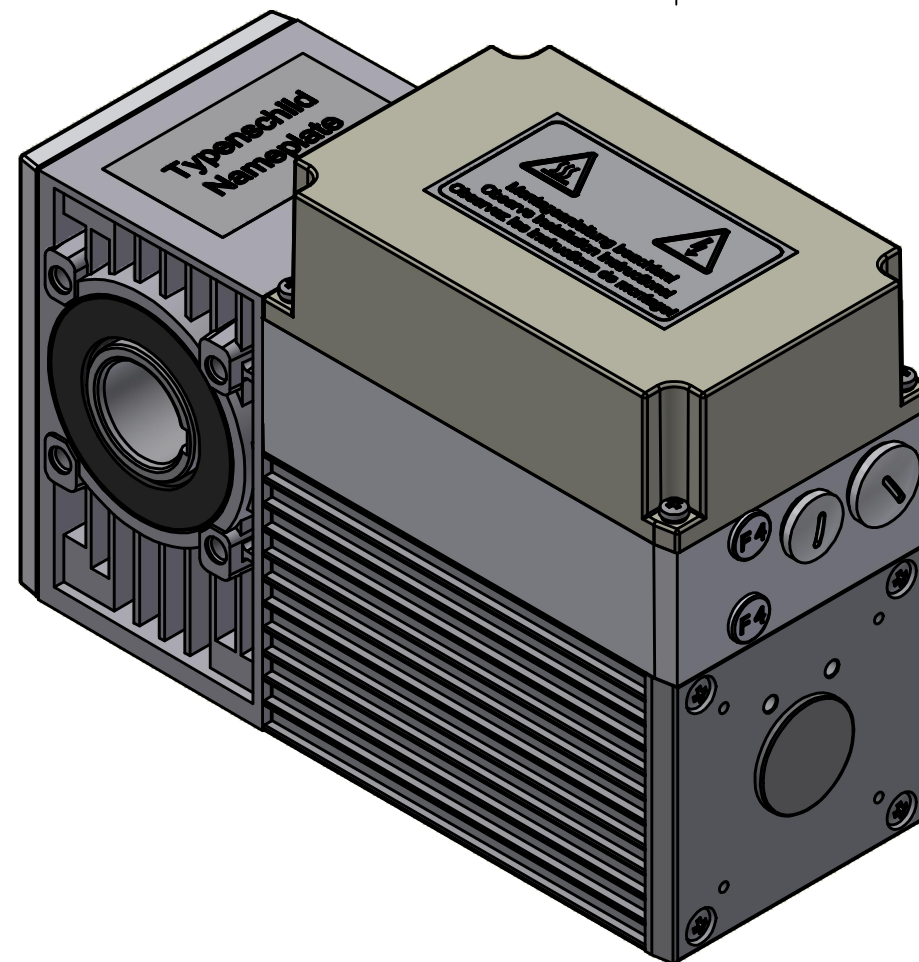

Bezeichnung / designation		Compacta MS12 Induction Motor	
Datenblatt / technical datasheet			
10000000000162356		 Franz Morat Group	
Artikel Nr. / article no. 6-12-MS-0025			
gezeichnet / drawn	Datum / date 26.09.2023	Name / name mwid	<b>Framo Morat GmbH &amp; Co. KG</b> Franz-Morat-Straße 6 D-79871 Eisenbach www.framo-morat.com