

Connection:
tapped hole
M16x1,5 + M20x1,5

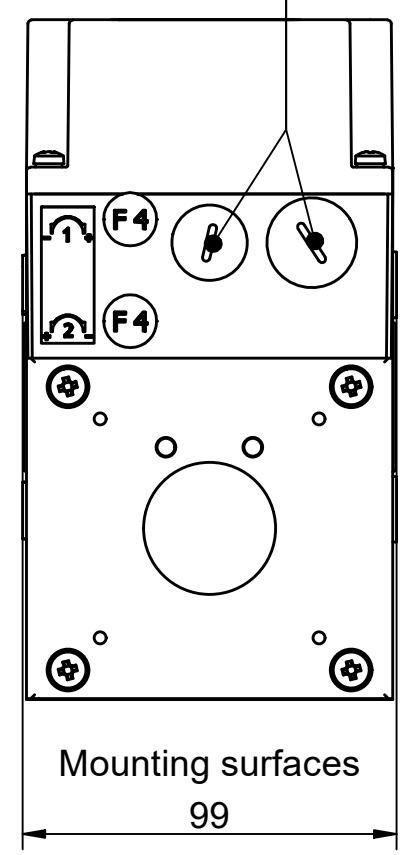

Configuration	
Description	Property value
Type	Compacta MS12
Mains	Three-phase current
Mains frequency	50 Hz
Y-Connection	Yes
Supply voltage	230/400V AC
Supply connection	3 x 400V AC
Output speed rpm	94,8 min ⁻¹
Output torque in Nm / Duty cycle (ED) in %	30 Nm / 40% 22,5 Nm / 60%
Duty cycle according to nameplate	40%
Self locking	No
Ratio	29 : 1
Lubrication	TRIBOL 800/680
First gear stage	Plastic
Limit switch range	34 revolutions on output
Protection class	IP54
Motor rating	0,4 kW
Current value	1,25 A
Equipment	
Anchor cone brake	
Rotary potentiometer 10 speeds 1kOhm	

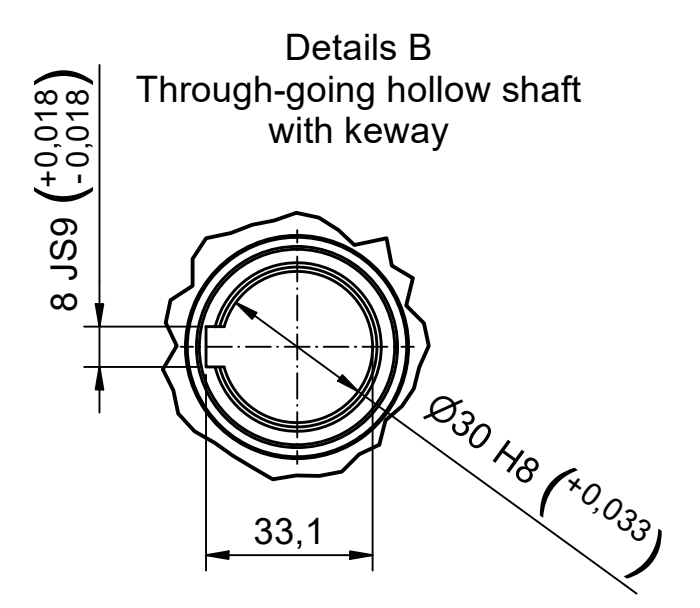
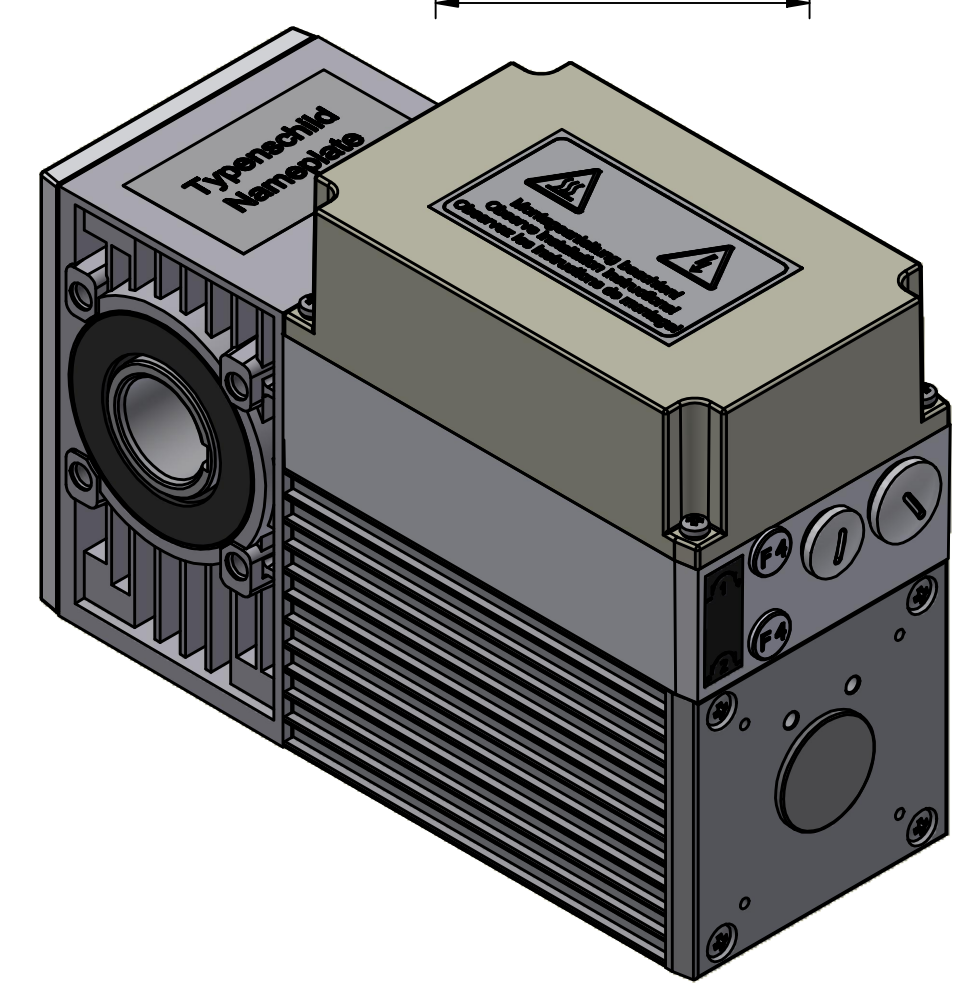
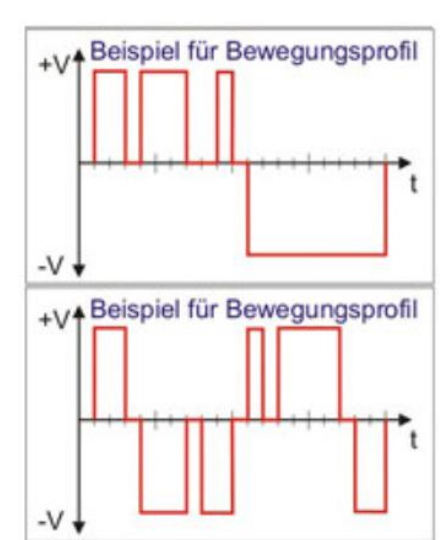
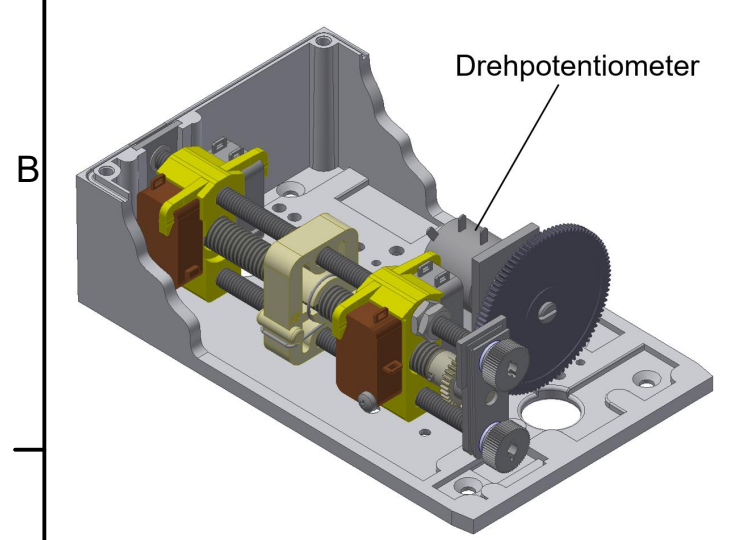

Safeguarded by 2 safety limit switches for applications with a defined end position in both directions of rotation.
Additional position signal using rotary potentiometers.

Bezeichnung / designation		Compacta MS12 Induction Motor	
Datenblatt / technical datasheet			
10000000000162342		 Franz Morat Group	
Artikel Nr. / article no. 6-12-MS-0019			
gezeichnet / drawn	Datum / date 25.09.2023	Name / name mwid	Framo Morat GmbH & Co. KG Franz-Morat-Straße 6 D-79871 Eisenbach www.framo-morat.com