

Connection:
tapped hole
M16x1,5 + M20x1,5

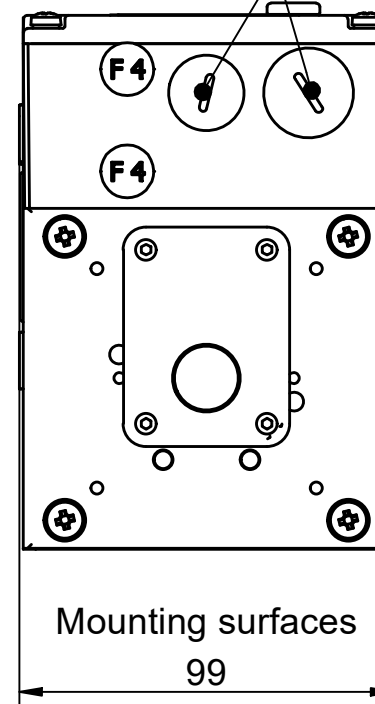

Configuration	
Description	Property value
Type	Compacta MS12
Mains	Three-phase current
Mains frequency	50 Hz
Y-Connection	Yes
Supply voltage	230/400V AC
Supply connection	3 x 400V AC
Output speed rpm	6,1 min ⁻¹
Output torque in Nm / Duty cycle (ED) in %	142 Nm / 40% 106,5 Nm / 60%
Duty cycle according to nameplate	60%
Self locking	dynamic
Ratio	225 : 1
Lubrication	TRIBOL 800/680
First gear stage	Bronze
Protection class	IP54
Motor rating	0,3 kW
Current value	1,3 A
Equipment	
Hand crank with electric protection	

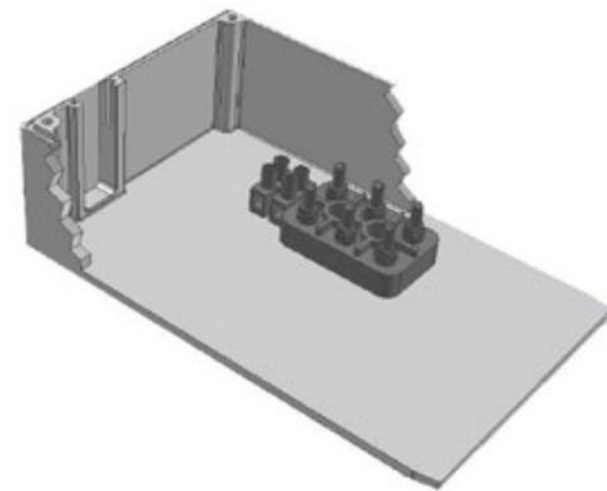

Terminal box (limit switch housing
without a switching mechanism).

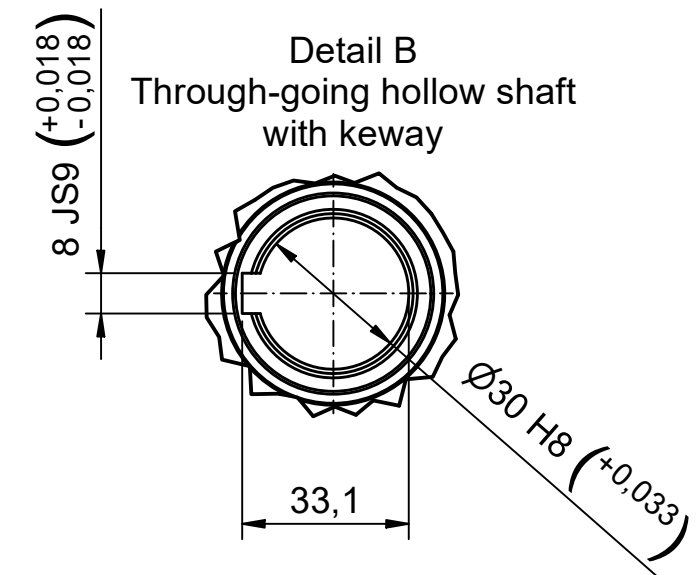
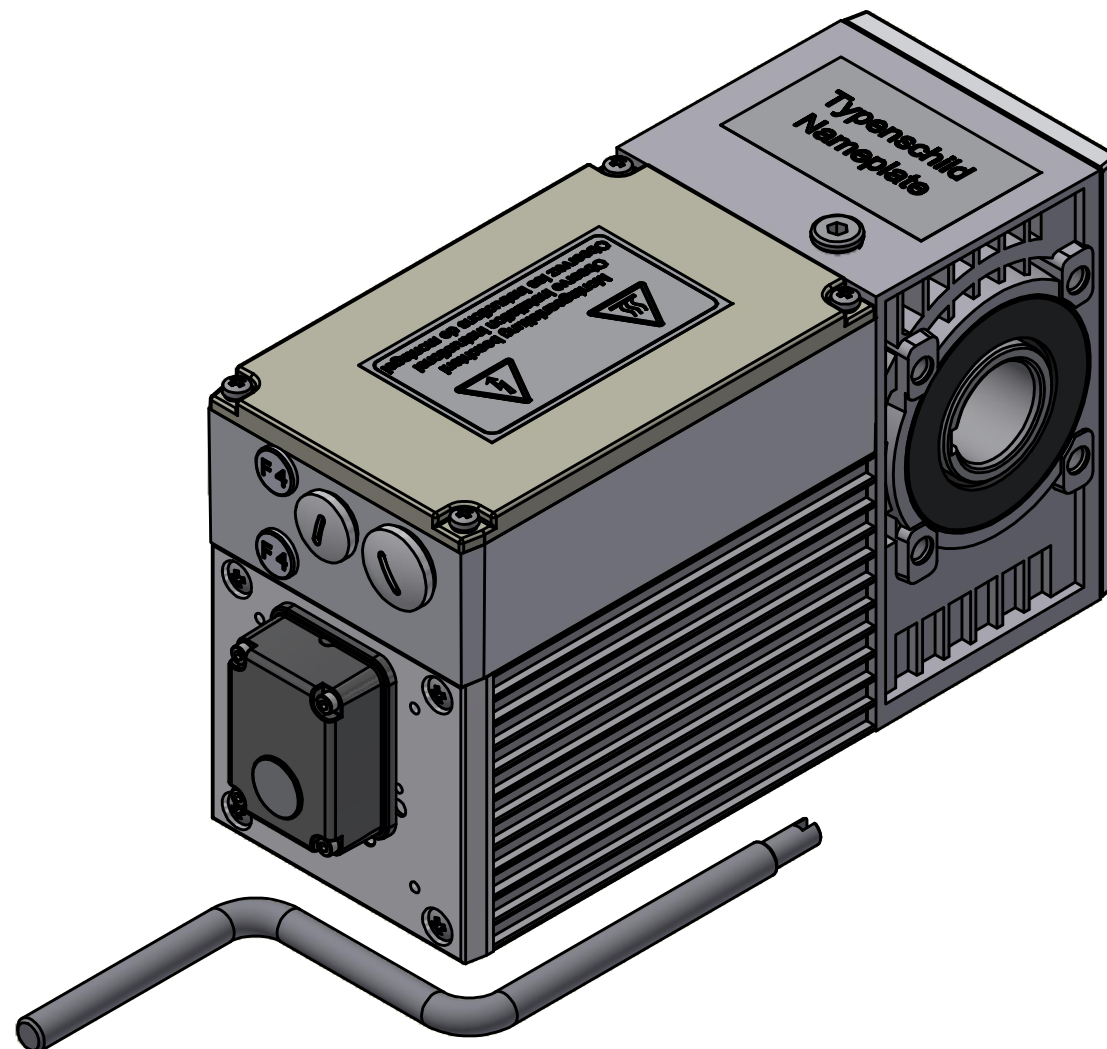

Bezeichnung / designation		
Compacta MS12 Induction Motor		
Datenblatt / technical datasheet		
10000000000162120		 Franz Morat Group
Artikel Nr. / article no. 6-12-MS-0002		
gezeichnet / drawn	Datum / date 13.09.2023	Name / name mwid
Framo Morat GmbH & Co. KG Franz-Morat-Straße 6 D-79871 Eisenbach www.framo-morat.com		